

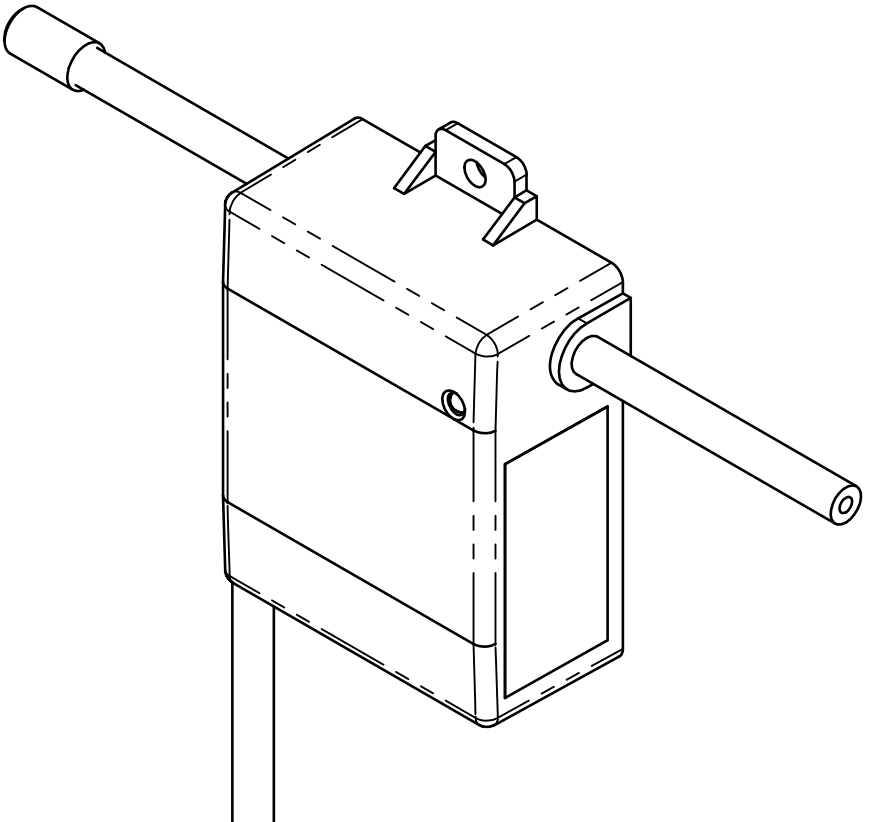

DEL OZONE® SPA

INSTALLATION INSTRUCTIONS & PRODUCT MANUAL
FOR MODEL XO3



THE COMPLETE MODERN SPA®
C-M-P.COM/SPA-SANITIZERS

IMPORTANT SAFETY INFORMATION: READ AND FOLLOW ALL INSTRUCTIONS

Save these instructions. Leave manual with homeowner after installation. Improper installation, adjustment, alteration, service, or lack of maintenance can cause injury or property damage. Read the installation, operating, & maintenance instructions thoroughly before installing or servicing this equipment.

IMPORTANT SAFETY INSTRUCTIONS

READ AND FOLLOW ALL INSTRUCTIONS

Read this manual completely before attempting installation. All permanent electrical connections should be made by a qualified electrician. Follow all applicable electrical codes.

⚠ DANGER Be sure the electrical power is shut OFF at the main circuit breaker before installing the DEL Ozone® Spa XO3.

NOTICE If the DEL Ozone® Spa XO3 electrical connection is to be attached to the spa controls, be sure the spa controls are protected by a Ground Fault Circuit Interrupter (G.F.C.I.). If the DEL Ozone® Spa XO3 is connected to an independent electrical supply, then a G.F.C.I. must be installed between the DEL Ozone® Spa XO3 and the electrical supply.

⚠ WARNING To reduce the risk of electrical shock, if the power cord is damaged, replace the entire unit immediately. The DEL Ozone® Spa XO3 must be located or fixed so that it cannot fall into the spa.

NOTICE The DEL Ozone® Spa XO3 must be mounted indoors or sheltered, under a cover, from natural elements (rain, sun, sprinklers). Mount the DEL Ozone® Spa XO3 so that it is inaccessible to anyone in the spa.

NOTICE Plastic ozone supply tubing is available with the DEL Ozone® Spa XO3. Never replace this tubing with metal tubing.

⚠ CAUTION Do not operate the DEL Ozone® Spa XO3 unless sufficient air flow is being drawn through the unit.

⚠ WARNING Short term inhalation of high concentrations of ozone and long term inhalations of low concentrations of ozone can cause harmful physiological effects. Do not inhale ozone gas produced by this device.

NOTICE This appliance can be used by children aged from 8 years and above and persons with reduced physical, sensory or mental capabilities or lack of experience and knowledge if they have been given supervision or instruction concerning use of the appliance in a safe way and understand the hazards involved. Children shall not play with the appliance. Cleaning and user maintenance shall not be made by children without supervision.

SAVE THESE INSTRUCTIONS!

TABLE OF CONTENTS

SECTION 1 Installation

1. Overview	2
2. Mounting.....	2
3. Plumbing	2
4. Electrical.....	3
5. Operation.....	3

SECTION 2 Maintenance

6. System Maintenance	3
-----------------------------	---

SUPPORT	6
----------------------	---

DIAGRAMS SHOWN IN THESE INSTRUCTIONS

page 2.....*DEL OZONE® TYPICAL MIXING SYSTEM*

page 5.....*DEL OZONE® SPA XO3 MOUNTING & CONNECTIONS*

SECTION 2 Maintenance

6. System Maintenance

a. Ordering Information:

To locate the dealer nearest you call 1-800-733-9060

Be prepared with the following information:

- Name
- Address
- Model #
- Date Purchased
- Dealer Name

b. Standard Replacement Parts List:

Ozone Check Valve (7-2108-01)

Ozone Tubing (7-0075)

The ozone check valve and tubing should be replaced annually.

- ### c. Regularly inspect ozone supply tubing for cracks or wear. Also check to make sure no water is present between the check valve and the ozone generator. This indicates check valve failure. Replace the ozone check valve and tubing immediately.

 **WARNING** Trace amounts of nitric acid may be present in the check valve or tubing and could be mildly corrosive. If condensation is present shut off the ozone generator and allow the moisture to be drawn out or dried up prior to servicing.

SAVE THESE INSTRUCTIONS

Record Information on this System Below & Keep for Your Records

Installer _____

System Purchased From _____

Installation Date _____

Serial Number _____

Model Number _____

CMP Customer Service & Tech Support

Toll Free: 1-800-733-9060

FAX: 770-632-7115

support@c-m-p.com

Warranty Questions

RMA@c-m-p.com

CMP, LLC
36 HERRING ROAD, NEWNAN, GA 30265
WWW.C-M-P.COM/DEL

0621ab