

Quick Start Card, S-CLASS™ spa systems

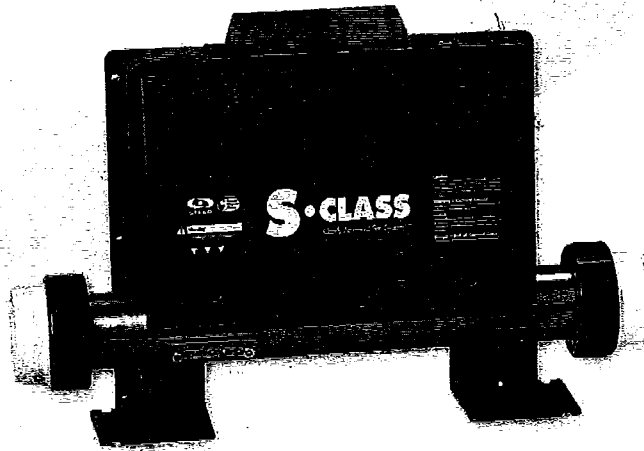

1- Connect all outputs & keypads

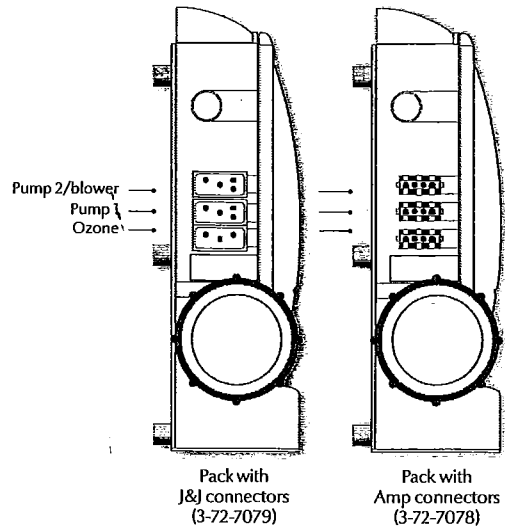
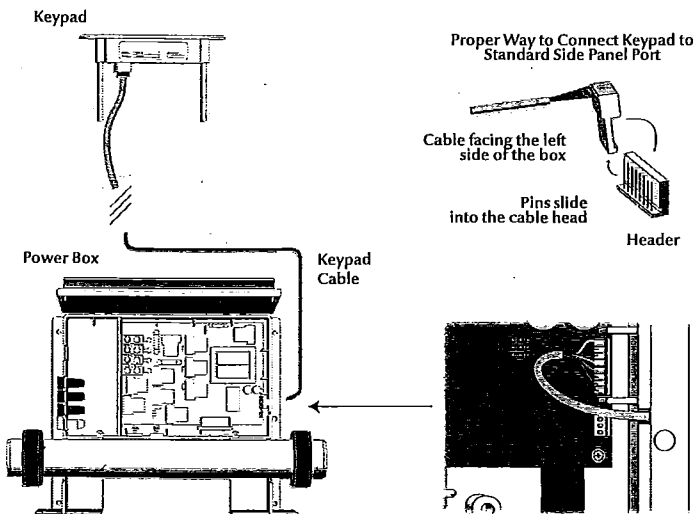

⚠ Clearance between Low and High Voltage conductors must be at least 1/4".

Connecting the temperature probe

The water temperature probe must be similarly connected to the power box, with cable following the same route as the main keypad.

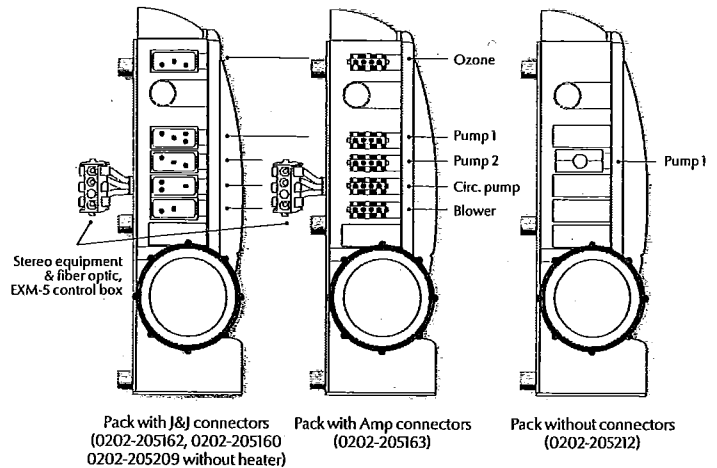
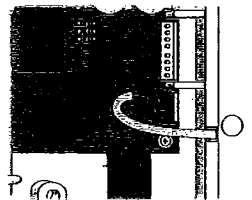

⚠ Make sure to connect all outputs with the proper output cable (120 or 240V), see wiring diagram inside the door.

2- Install temperature probe

Temperature probe holder (TPH-1)

Our patented temperature probe holder has been specially designed to securely position a temperature probe holder to spa side panel.

Installing the temperature probe holder

The probe holder should be installed below water level and be easily accessible.

- 1- Select an appropriate location for the temperature probe holder.
- 2- Drill a 7/8" (22 mm) diameter hole in the spa wall.
- 3- Assemble and install the holder to spa wall as shown. Hand tighten nut by turning counter-clockwise (should be tight enough to prevent any water leakage).

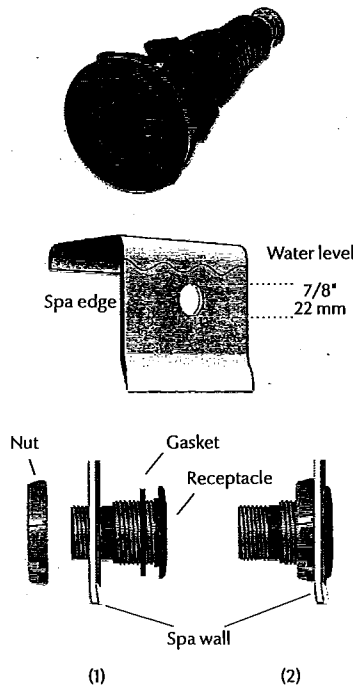

Installing the temperature probe

- 1- Insert probe into small end of strain relief and push completely through to other side. (a)
- Note: To ease the insertion, use a liquid and soap solution.
- 2- Force the stopper nut over the end of the strain relief so that it fits snugly. (b)
- 3- Insert the flat edge of probe into the strain relief. (c)
- 4- Insert probe assembly into the receptacle already installed on the spa wall and hand tighten. (d) Insert end-plug into small end of strain relief. (End-plug needs to be foamed over to prevent air temperature variations from affecting probe readings.)

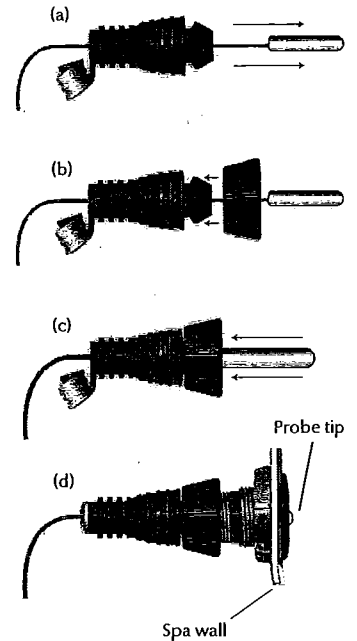

Note: Probe tip must slightly intrude into spa to ensure accurate temperature readings.

3- Select Jumper

Jumper configuration (0202-205162 & 0202-205209)

Jumper number	Function	Position 1 (left)	Position 2 (right)
JMP-1	Keypad	4x keys (K-9, K-18, k-19)	K-35
JMP-2	Blower	Installed	Not installed
JMP-3	Circ. pump	Installed	Not installed

Jumper configuration (0202-205163 & 0202-205160)

Jumper number	Function	Position 1 (left)	Position 2 (right)
JMP-1	Keypad	Standard	Reversed
JMP-2	Blower	Installed	Not installed
JMP-3	Circ. pump	Installed	Not installed

Jumper configuration (3-72-7079 & 3-72-7078)

Jumper number	Function	Position 1 (left)	Position 2 (right)
JMP-1	Input Current Mode	High current (HC)	Low Current (LC)
JMP-2	Temperature Units	Fahrenheit	Celsius
JMP-3	Pump #2 / Blower	Not installed	Installed

Jumper configuration (0202-205212)

Jumper number	Function	Position 1 (left)	Position 2 (right)
JMP-1	Input Current Mode	High current (HC)	Low Current (LC)
JMP-2	Pump #1	Dual speeds	Single speed
JMP-3	Circ. pump	Not installed	Installed

Note: Factory default values in bold

IMPORTANT NOTE: Unfortunately, there are two different color standards for two-speed pump wires. Some use the red wire for the high speed winding and others use the black wire.

It is important to have the proper wiring configuration.

You can only test it when the system is ready to use. To do so, lower the set point below the water temperature to turn the pump off (it will take 30 secs. for the pump to go off). Press Pump 1 key to manually turn on the pump. It should start in low speed and not high speed. If the pump starts in high speed, follow this procedure to correct the problem.

- 1) Turn the breaker off.
- 2) Locate the Pump 1 connectors (P101 and P14).
- 3) Using a pair of long-nose pliers, invert the connection of the black and red wires. Make sure the connectors are properly inserted.

4- Connect the pack to a GFCI breaker

Proper wiring of the electrical service box, GFCI box and pack terminal block is essential.

Refer to supplied wiring diagrams. Connections must be made by a certified electrician.

WARNING: TOTAL CURRENT OUTPUT CANNOT EXCEED TOTAL CURRENT INPUT RATING!

For 240 vac systems:

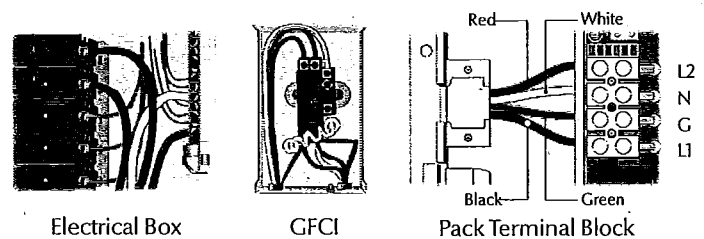

For 120 vac systems:

Not available on all S-CLASS contact techsupport@geckoal.com for further info.

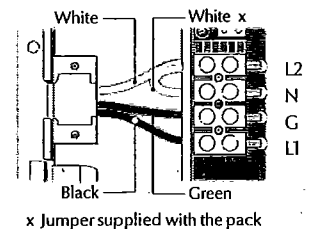

IMPORTANT NOTE: If you are not using a conduit for the power cable:

- 1) Remove the strain relief.
- 2) Connect the wires to the terminal block.
- 3) Install the strain relief and make sure it holds the cable firmly in place.